

13/LA/2019/R049 Bari AC

FORM 2B
(See rule 4)

NOMINATION PAPER

Election to the Legislative Assembly of ODISHA (State)

Handwritten notes:
Time - 11:11 AM
8/4/19

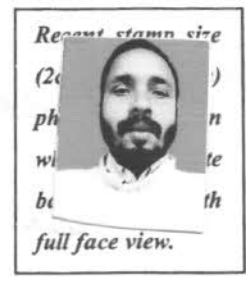

STRIKE OFF PART I OR PART II BELOW WHICHEVER IS NOT APPLICABLE

PART I

(To be used by candidate set up by recognised political party)

I nominate as a candidate for election to the Legislative Assembly from the.....Assembly Constituency.

Candidate's name.....Father's/mother's/husband's name.....His postal address.....

.....His name is entered at Sl. No.....in Part No.....of the electoral roll forAssembly constituency.

My name isand it is entered at Sl. No.in Part No.....of the electoral roll for the.....Assembly constituency.

Date

Signature of the Proposer

PART II

We hereby nominate as candidate for election to the Legislative Assembly from the 49 - BARI.....Assembly Constituency.

Candidate's name.....ASIT KUMAR RAY.....Father's/mother's/husband's name.....lt. GOKULANANDA RAY.....His postal address.....At - UPPER KAIPADA, PO - KAIPADA,

P.S. BARIRAMCHANDRAPUR, DIST. JAJPUR, 755010.....His name is entered at Sl. No.....643.....in Part No.....223.....of the electoral roll for49 - BARI.....Assembly constituency.

We declare that we are electors of this Assembly constituency and our names are entered in the electoral roll for this Assembly constituency as indicated below and we append our signatures below in token of subscribing to this nomination: -

Particulars of the proposers and their signatures

Sl.no.	Elector Roll No. of Proposer		Full Name	Signature	Date
	Part No. of Electoral Roll	S.No. in that part			
1	2	3	4	5	6
1.	223	331	RAJENDRA SAHU	Rajendra Sahu	8/4/2019
2.	223	636	SOUNDARYA KUMAR RAY	Soundarya Kumar Ray	8/4/19
3.	223	411	SUNANDRA PARIDA	Sunandra Parida	8/4/19
4.	223	907	DEBASIS PARIDA	Debashis Parida	8/4/19
5.	223	569	SUARNADEEP RAY	Suarnadeep Ray	8/4/19
6.	223	893	MANABINDA PARIDA	Manabinda Parida	8/4/2019
7.	223	251	MAADHANA SAHU	Maadha Sahu	8/4/2019
8.	223	670	PRAKASH CHANDRA RAY	Prakash Chandra Ray	8/4/2019
9.	223	682	SAMIRANTA RAY	Samiranta Ray	8/4/2019
10.	223	577	PRASANTA KUMAR PARIDA	Prasanta Kumar Parida	8/4/2019

N.B.- There should be ten electors of the constituency as proposers.

PART III

I, the candidate mentioned in Part I/Part II (Strike out which is not applicable) assent to this nomination and hereby declare that-

- (a) I am a citizen of India and have not acquired the citizenship of any foreign State;
- (b) that I have completed.....⁴⁰.....years of age;

[STRIKE OUT c(i) OR c(ii) BELOW WHICHEVER IS NOT APPLICABLE]

- (c) (i) I am set up at this election by theparty, which is recognised National Party/State Party in this State and that the symbol reserved for the above party be allotted to me.

OR HINDUSTAN NIRMAAN DAL

- (ii) I am set up at this election by theparty, which is a registered unrecognised political party/that I am contesting this election as an independent candidate. (Strike out which is not applicable) and that the symbols I have chosen, in order of preference, are: —

(i) WATER TANK (ii) (iii)

- (d) my name and my father's/mother's/husband's name have been correctly spelt out above in.....ENGLISH..... (name of the language); and

- (e) That to the best of my knowledge and belief, I am qualified and not also disqualified for being chosen to fill the seat in the Legislative Assembly of this State.

* I further declare that I am a member of the.....GENERAL.....**Caste/tribe which is a scheduled **caste/tribe of the State of.....ODISHA.....in relation to.....BARI.....(area) in that State.

I also declare that I have not been, and shall not be nominated as a candidate at the present general election/the bye-elections being held simultaneously, to the Legislative Assembly of (State) from more than two Assembly constituencies.

Date 08.04.2019

Asst Kumar RES
Signature of Candidate

* Score out this paragraph, if not applicable.

** Score out the words not applicable.

N.B.—A "recognised political party" means a political party recognised by the Election Commission under the Election Symbols (Reservation and Allotment) Order, 1968 in the State concerned.

PART IIIA

(To be filled by the candidate)

(1) Whether the candidate—

(i) has been convicted—

- (a) of any offence(s) under sub-section (1); or
- (b) for contravention of any law specified in sub-section (2) of section 8 of the Representation of the People Act, 1951 (43 of 1951); or

(ii) has been convicted for any other offence(s) for which he has been sentenced to imprisonment for two years or more.

Yes/No

If the answer is "Yes", the candidate shall furnish the following information:

- (i) Case/First information report No./Nos.
- (ii) Police station(s).....District(s).....State(s).....
- (iii) Section(s) of the concerned Act(s) and brief description of the offence(s) for which he has been convicted
- (iv) Date(s) of conviction(s).....
- (v) Court(s) which convicted the candidate.....
- (vi) Punishment(s) imposed [indicate period of imprisonment(s) and/or quantum of fine(s)]
- (vii) Date(s) of release from prison.....
- (viii) Was/were any appeal(s)/revision(s) filed against above conviction(s)..... Yes/No
- (ix) Date and particulars of the appeal(s)/application(s) for revision filed
- (x) Name of the court(s) before which the appeal(s)/application(s) for revision filed.....
- (xi) Whether the said appeal(s)/application(s) for revision has/have been disposed of or is/are pending.....
- (xii) If the said appeal(s)/application(s) for revision has/have been disposed of—
 - (a) Date(s) of disposal.....
 - (b) Nature of order(s) passed.....

- (2) Whether the candidate is holding any office of profit under the Government of India or State Government?..... (Yes/No) ✓
 -If Yes, details of the office held.....
- (3) Whether the candidate has been declared insolvent by any Court?..... (Yes/No) ✓
 -If Yes, has he been discharged from insolvency.....
- (4) Whether the candidate is under allegiance or adherence to any foreign country?..... (Yes/No) ✓
 -If Yes, give details.....
- (5) Whether the candidate has been disqualified under section 8A of the said Act by an order of the President?..... (Yes/No) ✓
 -If Yes, the period for which disqualified.....
- (6) Whether the candidate was dismissed for corruption or for disloyalty while holding office under the Government of India or the Government of any State?..... (Yes/No) ✓
 -If Yes, the date of such dismissal.....
- (7) Whether the candidate has any subsisting contract(s) with the Government either in individual capacity or by trust or partnership in which the candidate has a share for supply of any goods to that Government or for execution of works undertaken by that Government?..... (Yes/No) ✓
 -If Yes, with which Government and details of subsisting contract(s).....
- (8) Whether the candidate is a managing agent, or manager or Secretary of any company or Corporation (other than a cooperative society) in the capital of which the Central/ Government or State Government has not less than twenty-five percent share?..... (Yes/no) ✓
 -If Yes, with which Government and the details thereof.....
- (9) Whether the candidate has been disqualified by the Commission under section 10A of the said Act..... (Yes/No) ✓
 -If yes, the date of disqualification.....

Place: Jaipur
 Date: 08.04.2019

✓ Parit Kumar Roy
 Signature of the candidate

PART IV

(To be filled by the Returning Officer)

Serial No. of nomination paper 13/12A/2019/RO-49-Bari Ac
 This nomination was delivered to me at my office at 11:11 AM (hour) on 08.04.19 (date) by the *candidate/proposer (Name). Asit Kumar Roy

Date: 08.04.19

Returning Officer

*Score out the word not applicable.

Returning Officer.
 49-Bari,
 Assembly Constituency

PART V

Decision of Returning Officer Accepting or Rejecting the Nomination Paper

I have examined this nomination paper in accordance with section 36 of the Representation of the People Act, 1951 and decide as follows: —

.....
.....
.....

Date.....

Returning Officer

.....(Perforation).....

FORM A

Communication with regard to Authorised Persons to intimate names of Candidates set up by recognised NATIONAL OR STATE Political party or REGISTERED UN-RECOGNISED political party.

(See paragraph 13 (c), (d) and (e) of the Election Symbols
(Reservation and Allotment) Order, 1968.)

To

1. The Chief Electoral Officer,
... ODISHA (State/Union Territory).
2. The Returning Officer for the
49- BARI Constituency.

Subject:- General Elections to Legislative Assembly of 2019 from. ODISHA... (State/Union Territory) –
Allotment of Symbols - Authorisation of persons to intimate names of candidates.

Sir,

In pursuance of paragraph 13 (c), (d) and (e) of the Election Symbols (Reservation and Allotment) Order, 1968, I hereby communicate that the following person (s) has/have been authorised by the party, which is National Party/State Party in the State of ...N/A...../Registered Un-recognised Party to intimate the names of the candidates proposed to be set up by the party at the election cited above.

Name of person authorised to send notice	Name of office held in the party	District(s)/area (s) constituency/ constituencies in respect of which he has been authorised.
1	2	3
1. BISWARANJAN JETHY	PRESIDENT (ODISHA)	ALL CONSTITUENCY
2.		
3.		

HINDUSTHAN NIRMAN DAL

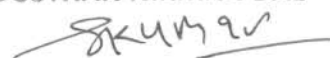

Shailendar Kumar Jain
National General Secretary

2. The specimen signatures of the above mentioned person (s) so authorised are given below:-

1. Specimen signatures of**BISWARANJAN JETHY**.....

(i) *Biswaranjan Jethy* (ii) *Biswaranjan Jethy*
(iii) *Biswaranjan Jethy*

2. Specimen signatures of Shri

(i) (ii)
(iii)

3. Specimen signatures of Shri

(i) (ii)
(iii)

Yours faithfully,
HINDUSTHAN NIRMAN DAL

Shailendar

Shailendar Kumar Jain
National General Secretary
SHAILENDER KUMAR JAIN
(NATIONAL GERNERAL SECRETARY)

President/Secretary
President/Secretary

Place *New Delhi*

Date *20.3.2019*

Name of the Party

(Seal of the Party)

NB.

1. This must be delivered to the Returning Officer and the Chief Electoral Officer not later than 3 p.m. on the last date for making nominations.
2. Form must be signed in ink by the office bearer (s) mentioned above. No facsimile signature or signature by means of rubber stamp, etc., of any office bearer shall be accepted.
3. No form transmitted by fax shall be accepted.

FORM B

NOTICE AS TO NAME OF CANDIDATE SET UP BY THE POLITICAL PARTY [SEE PARAGRAPHS 13(B), (C) AND (E) AND 13A OF THE ELECTION SYMBOLS (RESERVATION AND ALLOTMENT) ORDER 1968]

To

The Returning Officer for the

MA-BARI ASSEMBLY
..... Constituency.

Subject:- General Election to **Legislative Assembly 2019** from(Name of the Constituency) in**ODISHA**.....(State/Union territory) - setting up of candidate.

Sir,

In pursuance of paragraphs 13 (b), (c) and (e) and 13A of the Election Symbols (Reservation and Allotment) Order, 1968, I hereby give notice on behalf of **HINDUSTHAN NIRMAN DAL** (party)

- (i) that the person whose particulars are furnished in columns (2) to (4) below is the approved candidate of the party above named , and
- (ii) the person whose particulars are mentioned in columns (5) to(7) below is the substitute candidate of the party, who will step-in on the approved candidate's nomination being rejected on scrutiny or on his withdrawing from the contest, if the substitute candidate is still a contesting candidate,

at the ensuing general/bye election from this constituency :

Name of the Constituency	Name of the approved candidate	Father's/ Mother's/ Husband's name of approved candidate	Postal address of approved candidate	Name of the Substitute candidate who will step-in on the approved candidate's nomination being rejected on scrutiny or on his withdrawing from the contest if substitute candidate is still a contesting candidate	Father's/ Mother's/ Husband's name of substitute candidate	Postal address of substitute candidate
1	2	3	4	5	6	7
MA- BARI LEGISLATIVE ASSEMBLY CONSTITUENCY	ASIT KUMAR RAY	GOKULANANDA RAY	AT- UPPER KAIPADA, PO-KAIPADA, PS-BARI RAM CHANDRAPUR Dist-JAJPUR PIN- 755010 ODISHA	X	X	X



Biswanjan Jethy

- *2. The notice in FORM 'B' given earlier in favour of Shri/Smt./Sushri.....X.....as party's approved candidate/Shri/Smt./ SushriX.....as Party's substitute candidate is hereby rescinded.
3. It is certified that each of the candidates whose name is mentioned above is a member of this political party and his name is duly borne on the rolls of members of this party.

yours faithfully,

Biswaranjan Jethy

BISWARANJAN JETHY
PRESIDENT (ODISHA)



(Name and Signature of the
Authorised person of the party)

(Seal of the Party)

(Seal of the Party)

Place New Delhi

Date 20.3.2019

* Score off, if not applicable.

ELECTION COMMISSION OF INDIA**NirvachanSadan, Ashoka Road, New Delhi- 110001**

No.56/Symbol//LET/ECI/PP/PPS-II/2019/Vol.-IV

Date: 13th March, 2019

To

The Chief Electoral Officers of all States and Union Territories.

Sub:- General Elections to the House of the People, 2019- Concession to candidates set up by registered unrecognized political parties- allotment of common symbol under Para 10B of the Election Symbols (Reservation and Allotment) Order, 1968- Regarding.

Sir,

I am directed to state that the applications of the following 1 registered un-recognized political parties for concession in the allotment of a common symbol to their candidates being set up at the forthcoming General Election to the House of the People, 2019, under the provisions of Para 10B of the Election Symbols (Reservation and Allotment) Order, 1968, has been accepted by the Commission upon the direction given by Hon'ble High Court of Delhi in W.P No. 1839/2019 dated 07.03.2019. Accordingly, the Commission has decided to extend the concession sought under Para 10B to candidates of this party for the forthcoming General Election to the House of the People, 2019, in the constituencies mentioned as under: -

Sl. No.	Name of the Party	Name of Election(s)	No. of Parliamentary Constituencies in the respective State	Common Symbol allotted.
1.	Hindusthan Nirman Dal	House of the People, 2019	In all 543 Parliamentary Constituencies in All over India	Water Tank

2. The Returning Officers may be directed to allot the common symbol mentioned above to the candidates set up by the aforesaid registered un-recognized political party, subject to fulfillment of the provisions of Para 13 of the Election Symbols (Reservation and Allotment) Order, 1968 relating to setting up of candidates by the party. It may also be noted that said common symbol allotted to the candidates of the above mentioned political party, is not allotted by oversight to any other candidates in these constituencies. However, the said symbol shall be available for allotment as free symbol to other candidates in the constituencies where the aforesaid party does not actually set up its candidates.

3. In the event of the above said party failing to meet the requirement of the minimum number of candidates, as prescribed in Para 10B of the said Symbols Order, 1968, then the said common symbol shall not be available to its candidates.

Yours faithfully,

PRAMOD KUMAR SHARMA)
SECRETARY

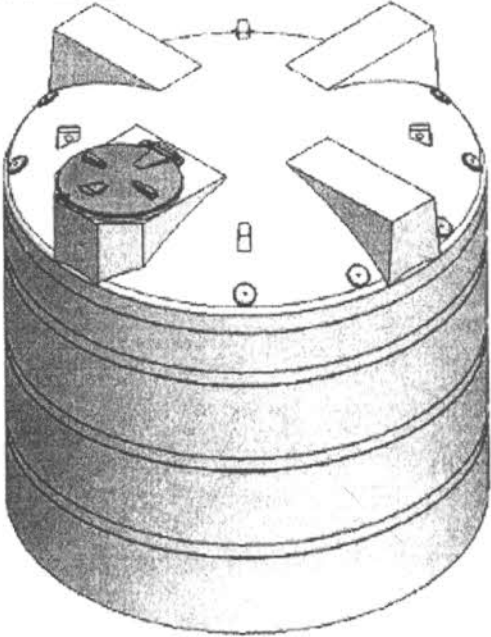
36.	Water Tank		
-----	------------	---	--



Biswaraj Jethy

ELECTION COMMISSION OF INDIA

Nirvachan Sadan, Ashoka Road, New Delhi-110001.

F. No. 56/41/2009/PPS-I

Dated: 7th January, 2010.

To

✓
/ 22/10
The President,
Hindusthan Nirman Dal,
House No. 100, Gali No. 5,
Krishna Nagar,
Safdarjang Enclave,
New Delhi.

Subject: - **"Hindusthan Nirman Dal"** - Registration under Section 29A of the Representation of the People Act, 1951, as a political party - Regarding.

Sir,

I am directed to state that the Election Commission of India, after having considered your application dated **15.12.2008** for registration of **"Hindusthan Nirman Dal"** as a political party and the documents produced in support of the statements/averments made/contained in the said application and the submissions made by authorized representative(s) of the party before the Commission on **18.12.2009** in respect of the said application, has registered the **"Hindusthan Nirman Dal"** as a political party under Section 29A of the Representation of the People Act, 1951 on and with effect from **18.12.2009**.

2. As provided in sub-Section (9) of Section 29A of the Representation of the People Act, 1951, the party shall communicate to the Commission without delay any change in its name, head office, office-bearers, address or in any other material matters. The Communication of such changers shall be accompanied by the following: -

- (i) An authenticated copy of the resolution passed by the competent body prescribed in the party constitution and the full proceedings of the meeting at which the decision of such changes is taken.
- (ii) Names of the office-bearers attending the said meeting.
- (iii) An attested copy of the extract of attendance register bearing signature of participating members in the said meeting.

3. It may be noted that the registration will not entitle the party to the reservation of any exclusive symbol for it. However, the candidates duly set up by the party at an election will be entitled to benefits of preference in allotment of free symbols over independent candidates under paragraph 12 of the Election Symbols (Reservation & Allotment) Order, 1968.

4. As per the provisions of Section 29B and 29C of the Representation of the People Act, 1951 (dealing with contribution to political parties) the party is required to submit to the Commission, a report of contribution received in excess of Rs. 20,000/- in a financial year, in the format in Form 24A appended to the Conduct of Election Rules, 1961. In such report, the party has to mention the Permanent Account Number (PAN) of the party. Therefore, you are advised to obtain Permanent Account Number (PAN) in respect of the party and inform the details of the same to the Commission within six months of the registration.

Yours faithfully,



(K.F. WILFRED)
SECRETARY

F. No. 56/41/2009/PPS-I

Dated, 7th January, 2010.

Copy:

- (i) The Chief Electoral Officer, National Capital Territory of Delhi, Delhi.
- (ii) The State Election Commissioner, National Capital Territory of Delhi, Delhi.
- (iii) Political Party Section-II
- (iv) Guard File.



(K.F. WILFRED)
SECRETARY

FORM OF OATH OR AFFIRMATION

[ARTICLE 173 (A) OF THE CONSTITUTION OF INDIA]

(To be made by a candidate for Election to the Legislature of a State)

I, ASIT KUMAR RAY.....having been nominated
as a candidate to fill a seat in the 49, B.P.T, AC.....Legislative
Assembly (*or Legislative Council) do swear in the name of the God/Solemnly affirm that I
will bear true faith and allegiance to the Constitution of India as by law established and that
I will uphold the sovereignty and integrity of India.

Asit Kumar Ray
Signature and name

in block letters of the candidate
ASIT KUMAR RAY

Sworn in the name of God/Solemnly affirmed by Shri/
Shrimati Asit Kumar Ray at Office Chamber of
(Place) at 11.15 AM (hour) this the 8th day
of April 2019 before me.

Chand
8/4/19
Signature of authorized person
Returning Officer.
Name, Designation and Seal
45 Bari
Assembly Constituency

Declaration by Candidate/Election agent/Proposer while submitting the
photograph of the Candidate

Election to Odisha Legislative Assembly from 49-Bari AC.

I ASIT KUMAR RAY S/o,D/o,H/o,W/o of
Sri GOKULANANDA RAY Nominated as candidate for the above
mentioned election am submitting herewith my photograph for the purpose of printing of the
same on the ballot paper. I declare that the photograph has been taken during the last 3 month
before the date of specification of election

(Fill of this part when the candidate himself is submitting the photograph)

OR

I Election agent /Proposer of Sri
S/o-D/o,W/o- Sri A candidate for the above
mentioned election, here by submit the photograph of the said candidate for the purpose of
printing the same on the ballot paper. I declare that the photograph has been taken during the
last 3 months before the date of notification of Election

(fill of this part when the election agent/proposer is submitting the photographs)

Date 08.04.2017

Name ASIT KUMAR RAY

Address AT-UPPER KATPAJA, PO-KATPAJA
DIST-JAJPUR, PIN-758010

TelephoneNo 9437926746

Asit Kumar Ray

FORM OF OATH OR AFFIRMATION

[ARTICLE 173 (A) OF THE CONSTITUTION OF INDIA]

(To be made by a candidate for Election to the Legislature of a State)

I, ASIT KUMAR RAY.....having been nominated as a candidate to fill a seat in the 49 - BARI.....Legislative Assembly (*or Legislative Council) do swear in the name of the God/Solemnly affirm that I will bear true faith and allegiance to the Constitution of India as by law established and that I will uphold the sovereignty and integrity of India.

Asit Kumar Ray
ASIT KUMAR RAY
Signature and name

in block letters of the candidate

Sworn in the name of God/Solemnly affirmed by Shri/
Shrimati Asit Kumar Ray at 11:15 Am
(Place) at 11:15 Am, 8.4.19 (hour) this the 8th day
of April 2019 before me.

Signature of authorized person
Returning Officer.
Name, Designation and Seal
49-Bari,
Assembly Constituency

(CERTIFICATE FOR RECEIPT OF OATH)

(To be handed over to the candidate by the authorized person)

Certified that ASIT KUMAR RAY.....(name) a candidate for election to the 49 - BARI.....Legislative Assembly (*or Legislative Council) has made and subscribed the oath/ affirmation as required by the Constitution of India before me at my office at 49-Bari.....(hour) on 8.4.19.....(date).

Signature of authorized person
Returning Officer.
Name, Designation and Seal
49-Bari,
Assembly Constituency

*Score out which is not applicable.

N.B. :—This Form should be supplied to the candidates both in English and in the Official Language of the State.

ରସିଦ ପୁସ୍ତକ
RECEIPT BOOK

196734

ସଂ. _____

[ଓଡ଼ିଶା ନିକାରତ ପ୍ରକରଣ ପୁସ୍ତକ, 1963 ନିୟମ 31(i) ଦ୍ରଷ୍ଟବ୍ୟ]

ପୁସ୍ତକ ସଂ. 22/90en ମସିହା 20

କାହାଠାରୁ ପ୍ରାପ୍ତ ହେଲା ଧର୍ମେ କୁମାର ସିଂହ

କେଉଁ ବାବଦରେ ଟନ - ଜଣୀ ସିନାମସ୍ତ୍ରୀ ମହଲୀ ପାହାଁ
ମନୋନୟନ ପତ୍ର ମାଧ୍ୟମରେ ନିମନ୍ତ୍ରଣ

ନଗଦ ଆକାରରେ ଟ ୧୦.୦୦। ପରିମାଣ
ଟ. ପ.

ସ୍ୱାମୀ ଆକାରରେ _____

ମୋଟ ଟ ୧୦.୦୦।

(ଅକ୍ଷରରେ ଦଶ ହଜାର ଟଙ୍କା ମାତ୍ର)

ତା ୦୪/୦୪/200en

ସୁଧାଂଶୁ ଜେନା

କାଶିୟର (Election)
Collectorate, Jajpur

New

Generally used abbreviations

a/c = Account	dep = Deposit	Pr = Principal
adj = Adjustment	Dft = Draft	proc = Processing Change
Amt = Amount	dish/dsh = Dishonour	rd = Recurring Deposit
Ar = Arrear	DR = Debit	ret/rtn = Return
bal = Balance	DoB = Date of Birth	Rnd = Round of
Capn = Capitalization	eft = Electronic Fund Transfer	sb = Saving Bank
chg/ch = Charge	Inop = Inoperative	SC = Short Credit
chq = Cheque	ins = Insurance	SI/So/SORD = Standing Instruction
Clos = Closure	int/in = Interest	S/D/W/H/o = Son/Daughter/Wife/Husband of
coll = Collection	lon/ln = Loan	tr/trf/xfer = Transfer
comm = Commision	min = Minimum	TT = Telegraphic Transfer
COR/CORR = Correction	os = Outstanding	txn = Transaction
CR = Credit	P & T = Postage & Telegram	Wdl = Withdrawal
csh = Cash	Pos = Point of sale	+ MOD bal = total balance (SB+linked MOD a/c)

भारतीय स्टेट बैंक

State Bank of India

REGULAR SB CHO-INDIVIDUALS

CIF No : 81435719802
Account No : 38374287270

Customer Name: Mr. ASIT KUMAR RAY

KAIPADA
AT/PO-KAIPADA

S/D/W/H/o: LATE GOKULANANDA RAY

Address: UPPER KAIPADA

KAIPADA

BARI

Phone:

Email:

D.O.B. (If Minor):

MOP.: SINGLE

Nom. Reg. No.:



Phone: 212604

Email: sa.08092@sbi.co.in

Branch Code: 8092

Date of Issue: 05/04/2019

05/04/2019 3114279 8092

IFSC: SBIN0008092

MICR: 755002509
Branch Manager

CONTINUATION



Asit Kumar Ray

DATE

PARTICULARS

CHEQUE NO.

DEBIT

CREDIT

BALANCE

05.04.19 CASH DEPOSIT SELF

1200.00

1200.00Cr

Uncl Bal: 0.00 Clr Bal: 1200.00 Cr:+MOD BAL: 0.00

Post kumar RY

भारतीय गैर न्यायिक

दस
रुपये

TEN
RUPEES

10

Rs.10



INDIA NON JUDICIAL



BEFORE THE NOTARY PUBLIC : JAJPUR

AFFIDAVIT

FORM 26

(See rule 4A)

Affidavit filed by the candidate alongwith nomination paper before the returning officer for election to **ODISHA LEGISLATIVE ASSEMBLY** (name of the House) from **49 - Bari Assembly constituency** (Name of the Constituency)

PART-A

I, **Asit Kumar Ray**, son of **Gokulananda Ray**, Aged **40** years, resident of **Vill-Upperkaipada, P.O. Kaipada, P.S. Bari Ramachandrapur, Dist. Jajpur, Odisha, Pin - 755010**, (mention full postal address), a candidate at the above election, do hereby solemnly affirm and state on oath as under:-

(1) I am a candidate set up by **Hindustan Nirman Dala**.

(** name of the political party)** am contesting as an Independent candidate.

(** strike out whichever is not applicable)

(2) My name is enrolled in **49 - Bari Assembly constituency** (Name of the constituency and the State), at Serial No. **643** in Part No. **223**.

(3) My contact telephone number (s) is/are **9437926746/7609911171** and my e-mail id (if any) is **asitray78@gmail.com** and my social media account(s) (if any) is/are

(i) **Facebook - asitray78@gmail.com.**

(ii) **Whatsapp - 7609911171**

(iii) Nil

Asit Kumar Ray

Sarat Ku. Panigrahi
Notary Public, Jajpur, Odisha, P.2.

Subscribed by me
Asit Kumar Ray



no 2320
4.4.2019

ASST Ks Pgt to ~~Mr. Anand~~ & Banker

Dist. 4/2/95

DA
1/0

Janardan Deo
Stamp Vendor
Civil Court Jaipur LD 5

RECEIVED
PUBLIC TREASURY OFFICER
JAIPUR

Sl. No	Names	PAN	The financial year for which the last Income-tax return has been filed	Total income shown in Income Tax Return (in Rupees) for the last five Financial Years (as on the 31st March)	
1.	Self - ASIT KUMAR RAY	ATAAR7795N	2018-19	(i)	102650/-
				(ii)	NIL
				(iii)	NIL
				(iv)	NIL
				(v)	NIL
2.	Spouse UNMARRIED	NIL	NIL	(i)	NIL
				(ii)	NIL
				(iii)	NIL
				(iv)	NIL
				(v)	NIL
3.	HUF (If Candidate is Karta/Coparcener)	NO PAN Allotted	NIL	(i)	NIL
				(ii)	NIL
				(iii)	NIL
				(iv)	NIL
				(v)	NIL
4.	Dependent - 1 - MOTHER SNEHALATA RAY	NO PAN ALLOTTED	NIL	(i)	NIL
				(ii)	NIL
				(iii)	NIL
				(iv)	NIL
				(v)	NIL
5.	Dependent - 2 NIL	NIL	NIL	(i)	NIL
				(ii)	NIL
				(iii)	NIL
				(iv)	NIL
				(v)	NIL
6.	Dependent - 3 NIL	NIL	NIL	(i)	NIL
				(ii)	NIL
				(iii)	NIL
				(iv)	NIL
				(v)	NIL

Note : It is mandatory for PAN holder to mention PAN and in case of no PAN, it should be clearly stated "No PAN allotted".

Contd.P.3.

 Sarat Ku. Panigrahi
 Notary Public, Jaipur
 064-19

Pratik Kumar 17/05

(5) Pending criminal cases

I declare that there is no pending criminal case against me. (Tick this alternative if there is no criminal case pending against the Candidate and write NOT APPLICABLE against alternative (ii) below)

OR

(ii) **The following criminal cases are pending against me:**

(If there are pending criminal cases against the candidate, then tick this alternative and score off alternative (i) above, and give details of all pending cases in the Table below)

Table

(a)	FIR No. with name and address of Police Station concerned	NOT APPLICABLE	NIL	NIL
(b)	Case No. with Name of the Court	NOT APPLICABLE	NIL	NIL
(c)	Section(s) of concerned Acts/Codes involved (give no. of the Section, e.g. Section of IPC, etc.).	NOT APPLICABLE	NIL	NIL
(d)	Brief description of offence	NOT APPLICABLE	NIL	NIL
(e)	Whether charges have been framed (mention YES or NO)	NOT APPLICABLE	NIL	NIL
(f)	If answer against (e) above is YES, then give the date on which charges were framed	NOT APPLICABLE	NIL	NIL
(g)	Whether any Appeal/Application for revision has been filed against the proceedings (Mention YES or NO)	NOT APPLICABLE	NIL	NIL

Contd.P.4

06-4-19
Sarat Ku. Panigrahi
Notary Public, Jaipur

Prat Kumar 1/5

(6) Cases of conviction

I declare that I have not been convicted for any criminal offence. (Tick this alternative, if the candidate has not been convicted and write NOT APPLICABLE against alternative (ii) below)

OR

(ii) I have been convicted for the offences mentioned below:

(If the candidate has been convicted, then tick this alternative and score off alternative (i) above, and give details in the Table below)

Table

(a)	Case No.	NOT APPLICABLE	NIL	NIL
(b)	Name of the Court	NOT APPLICABLE	NIL	NIL
(c)	Sections of Acts/Codes involved (give no. of the Section, e.g. Section of IPC, etc.).	NOT APPLICABLE	NIL	NIL
(d)	Brief description of offence for which convicted	NOT APPLICABLE	NIL	NIL
(e)	Dates of orders of conviction	NOT APPLICABLE	NIL	NIL
(f)	Punishment imposed	NOT APPLICABLE	NIL	NIL
(g)	Whether any Appeal has been filed against conviction order (Mention YES or No)	NOT APPLICABLE	NIL	NIL
(h)	If answer to (g) above is YES, give details and present status of appeal	NOT APPLICABLE	NIL	NIL

(6A) I have given full and up-to-date information to my political party about all pending criminal cases against me and about all cases of conviction as given in paragraphs (5) and (6).

[candidates to whom this Item is not applicable should clearly write **NOT APPLICABLE IN VIEW OF ENTRIES IN 5(i) and 6(i), above**]

Note:

1. Details should be entered clearly and legibly in BOLD letters.
2. Details to be given separately for each case under different columns against each item.
3. Details should be given in reverse chronological order, i.e., the latest case to be mentioned first and backwards in the order of dates for the other cases.
4. Additional sheet may be added if required.
5. Candidate is responsible for supplying all information in compliance of Hon'ble Supreme Court's judgment in W. P (C) No. 536 of 2011.

Contd.P.5

Sarat Ku. Panigrahi
Notary Public, Jajpur

Post number 8900



(7) That I give herein below the details of the assets (movable and immovable etc.) of myself, my spouse and all dependents:

A. Details of movable assets:

- Note: 1. Assets in joint name indicating the extent of joint ownership will also have to be given.
- Note: 2. In case of deposit/investment, the details including Serial Number, Amount, date of deposit, the scheme, Name of the Bank/Institution and Branch are to be given
- Note: 3. Value of Bonds/Share Debentures as per current market value in Stock Exchange in respect of listed companies and as per books in case of non-listed companies should be given.
- Note: 4. 'Dependent' means parents, son(s), daughter(s) of the candidate or spouse and any other person related to the candidate whether by blood or marriage, who have no separate means of income and who are dependent on the candidate for their livelihood.
- Note: 5. Details including amount is to be given separately in respect of each investment.
- Note: 6. Details should include the interest in or ownership of offshore assets.

Explanation,- For the purpose of this Form, the expression "offshore assets" includes, details of all deposits or investments in Foreign banks and any other body or institution abroad, and details of all assets and liabilities in foreign countries';

S. No.	Description	Self	Spouse	HUF	Dependent-1	Dependent-2	Dependent-3	
(i)	Cash in hand	8000/-	NIL	NIL	NIL	NIL	NIL	
(ii)	Details of deposit in Bank accounts (FDRs, Term Deposits and all other types of deposits including saving accounts), Deposits with Financial Institutions, Non-Banking Financial Companies and Cooperative societies and the amount in each such deposit.	FDR No-3806 5345767 of Rs-100000/- dt: 12-11-18 AL-SBI-KAIPADA BRANCH. F.DRAB-38090 594483 dt: 27-11-18 SBI KAIPADA BRANCH of Rs-1,00,000/- SBI SBA/C No-1174953 2239-9378/ Corporation BANK A/C No-520101 053660151- 1170/- SBI-A/C No- - Rs 1200/-	NIL	NIL	NIL	NIL	NIL	NIL

Handwritten signature/initials

Contd.P.6

Sarat K. Panigrahi
 Notary Public, Jaipur

Handwritten signature/initials

S. No.	Description	Self	Spouse	HUF	Dependent-1	Dependent-2	Dependent-3
(iii)	Details of investment in Bonds, debentures/shares and units in companies/ Mutual funds and others and the amount	NIL	NIL	NIL	NIL	NIL	NIL
(iv)	Details of investment in NSS, Postal Saving, Insurance policies and investment in any Financial instruments in Post office or Insurance Company and the amount	NIL	NIL	NIL	NIL	NIL	NIL
(v)	Personal loans/advance given to any person or entity including firm, company, Trust etc., and other receivables from debtors and the amount	NIL	NIL	NIL	NIL	NIL	NIL
(vi)	Motor Vehicles/ Aircrafts/Yachts/Ships (Details of Make, registration number, etc. year of purchase and amount)	NIL	NIL	NIL	NIL	NIL	NIL
(vii)	Jewellery, bullion and valuable thing(s) (give details of weight and value)	NIL	NIL	NIL	NIL	NIL	NIL
(viii)	Any other assets such as value of claims/interest	NIL	NIL	NIL	NIL	NIL	NIL
(ix)	Gross Total Value	Rs. 219748	NIL	NIL	NIL	NIL	NIL

Contd.P.7

Donnet

Sarat Ku. Panigrahi
Notary Public, Jaipur

Adit Kumar RS

B. Details of Immovable Assets:

- Note: 1. Properties in joint ownership indicating the extent of joint ownership will also have to be indicated
 Note: 2. Each land or building or apartment should be mentioned separately in this format.
 Note: 3. Details should include the interest in or ownership of offshore assets.

S. No.	Description	Self	Spouse	HUF	Dependent-1	Dependent-2	Dependent-3
(i)	<u>Agricultural Land</u> Location(s) Survey number(s)	NIL	NIL	UPPER KALPADA Khat. No- 145, 125, 271, 146,	NIL	NIL	NIL
	Area (total measurement in acres)	NIL	NIL	Ac 12.95 do	NIL	NIL	NIL
	Whether inherited property (Yes or No)	NIL	NIL	Yes	NIL	NIL	NIL
	Date of purchase in case of self-acquired property	NIL	NIL	NIL	NIL	NIL	NIL
	Cost of Land (in case of purchase) at the time of purchase	NIL	NIL	NIL	NIL	NIL	NIL
	Any investment on the land by way of development, construction etc.	NIL	NIL	NIL	NIL	NIL	NIL
	Approximate current market value	NIL	NIL	25,99,000	NIL	NIL	NIL
(ii)	<u>Non-Agricultural Land:</u> Location(s) Survey number(s)	NIL	NIL	UPPER KALPADA Khat. No- 125, 145	NIL	NIL	NIL
	Area (total measurement in sq.ft.)	NIL	NIL	Ac 0.85	NIL	NIL	NIL

D. D. 06.4.19

Sarat Ku. Panigrahi,
Notary Public, Jaipur

06.4.19

S. No	Description	Self	Spouse	HUF	Dependent-1	Dependent-2	Dependent-3
	Whether inherited property (Yes or No)	NIL	NIL	YES	NIL	NIL	NIL
	Date of purchase in case of self-acquired property	NIL	NIL	NIL	NIL	NIL	NIL
	Cost of Land (in case of purchase) at the time of purchase	NIL	NIL	NIL	NIL	NIL	NIL
	Any investment on the land by way of development, construction etc.	NIL	NIL	Rs 5,00,000 for House construction	NIL	NIL	NIL
	Approximate current market value.	NIL	NIL	RS 1350000	NIL	NIL	NIL
(iii)	Commercial Buildings (including apartments)- Locations(s)- Survey number(s)	NIL	NIL	NIL	NIL	NIL	NIL
	Area (total measurement in sq.ft.)	NIL	NIL	NIL	NIL	NIL	NIL
	Built-up Area (total measurement in sq.ft.)	NIL	NIL	NIL	NIL	NIL	NIL
	Whether inherited property (Yes or No)	NIL	NIL	NIL	NIL	NIL	NIL
	Date of purchase in case of self-acquired property	NIL	NIL	NIL	NIL	NIL	NIL
	Cost of property (in case of purchase) at the time of purchase	NIL	NIL	NIL	NIL	NIL	NIL

Contd.P.9

Daniel

 08-4-19
 Sarat Ku. Panigrahi
 Notary Public, Jaipur

Part 2 of 2

S. No.	Description	Self	Spouse	HUF	Dependent-1	Dependent-2	Dependent-3
	Any investment on the property by way of development, construction, etc.	NIL	NIL	NIL	NIL	NIL	NIL
	Approximate current market value	NIL	NIL	NIL	NIL	NIL	NIL
(iv)	Residential Buildings (including apartments):- Location(s)- Survey number(s)	NIL	NIL	UPPER KALIPADA Kharaba No- 125 Pkt No- 1648	NIL	NIL	NIL
	Area (total measurement in sq.ft.)	NIL	NIL	2500 sqft	NIL	NIL	NIL
	Built-up Area (Total measurement in sq.ft.)	NIL	NIL	1250 sqft	NIL	NIL	NIL
	Whether inherited property (Yes or No)	NIL	NIL	Yes	NIL	NIL	NIL
	Date of purchase in case of self-acquired property	NIL	NIL	NIL	NIL	NIL	NIL
	Cost of property (in case of purchase) at the time of purchase	NIL	NIL	NIL	NIL	NIL	NIL
	Any investment on the land by way of development, construction etc.	NIL	NIL	Rs 500000- for construct	NIL	NIL	NIL
	Approximate current market value	NIL	NIL	Rs 2000000	NIL	NIL	NIL
(v)	Others (such as interest in property)	NIL	NIL	NIL	NIL	NIL	NIL
(vi)	Total of current market value of (i) to (v) above	NIL	NIL	Rs 7000000	NIL	NIL	NIL

Dam

Contd.P.10

SB
06-4-19
Sarat Ku. Panigrahi
Notary Public, Jaipur

Dr. Kumar 92

(8) I give herein below the details of liabilities/dues to public financial institutions and government:-

(Note: please give separate details of name of bank, institution, entity or individual and amount before each item)

S. No.	Description	Self	Spouse	HUF	Dependent-1	Dependent-2	Dependent-3
(i)	Loan or dues to Bank/financial institution(s) Name of Bank or Financial Institution, Amount outstanding, Nature of Loan	NIL	NIL	NIL	NIL	NIL	NIL
	Loan or dues to any other individuals/entity other than mentioned above Name(s), Amount outstanding, nature of loan	NIL	NIL	NIL	NIL	NIL	NIL
	Any other liability	NIL	NIL	NIL	NIL	NIL	NIL
	Grand total of liabilities	NIL	NIL	NIL	NIL	NIL	NIL
(ii)	Government dues: Dues to departments dealing with Government accommodation	<p>(A) Has the Deponent been in occupation of accommodation provided by the Government at any time during the last ten years before the date of notification of the current election?</p> <p>(B) If answer to (A) above is YES, the following declaration may be furnished namely:-</p> <p>(i) The address of the Government accommodation: NOT APPLICABLE</p> <p>(ii) There is no dues payable in respect of above Government accommodation, towards-</p> <p>(a) rent; NIL (b) electricity charges; NIL (c) water charges; and NIL (d) telephone charges as on NIL (date) [the date should be the last date of the third month prior to the month in which the election is notified or any date thereafter].</p> <p>Note- 'No Dues Certificate' from the agencies concerned in respect of rent, electricity charges, water charges and telephone charges for the above Government accommodation should be submitted.</p>					YES/NO (Pl. tick the appropriate alternative)
							NO

Diomed

Contd.P.11

Sarat Ku. Panigrahi
06-4-19
Member Public, Jaipur

Prat Kumar 179



S. No.	Description	Self	Spouse	HUF	Dependent-1	Dependent-2	Dependent-3
(iii)	Dues to department dealing with Government transport (including aircrafts and helicopters)	NIL	NIL	NIL	NIL	NIL	NIL
(iv)	Income tax dues	NIL	NIL	NIL	NIL	NIL	NIL
(v)	GST dues	NIL	NIL	NIL	NIL	NIL	NIL
(vi)	Municipal/ Property Tax dues	NIL	NIL	NIL	NIL	NIL	NIL
(vii)	Any other dues	NIL	NIL	NIL	NIL	NIL	NIL
(viii)	Grand total of all Government dues	NIL	NIL	NIL	NIL	NIL	NIL
(ix)	Whether any other liabilities are in dispute, if so, mention the amount involved and the authority before which it is pending	NIL	NIL	NIL	NIL	NIL	NIL

(9) Details of profession or occupation:

- (a) Self FARMER
- (b) Spouse NOT APPLICABLE (UNMARRIED)

Contd.P.12

Dammal

Sarat Ku. Panigrahi
06-4-19
Notary Public, Jaipur

Post number 90

(9A) Details of source(s) of income:

(a) Self *From Agriculture*

(b) Spouse *NOT APPLICABLE (Unmarried)*

(c) Source of income, if any, of dependents *Mother Pension Holder*

(9B) Contracts with appropriate Government and any public company or companies

(a) details of contracts entered by the candidate *NIL*

(b) details of contracts entered into by spouse *NIL*

(c) details of contracts entered into by dependents *NIL*

(d) details of contracts entered into by Hindu Undivided Family or trust in which the candidate or spouse or dependents have interest *NIL*

(e) details of contracts, entered into by Partnership Firms in which candidate or spouse or dependents are partners *NIL*

(f) details of contracts, entered into by private companies in which candidate or spouse or dependents have share *NIL*

(10) My educational qualification is as under:-

..... *BACHELOR OF ARTS (ECONOMICS HONOURS) In YEAR-1998 FROM -*
..... *DHARANIDHAR COLLEGE, KEONJHAR, FROM - UTKAL UNIVERSITY*

(Give details of highest School/University education mentioning the full form of the certificate/ diploma/degree course, name of the School/College/University and the year in which the course was completed.)

Panel

Contd.P.13

Sf
Feb. 4-19
Sarat Ku. Panigrahi
Notary Public, Jaipur

Prat Kumar 19

PART-B

(11) ABSTRACT OF THE DETAILS GIVEN IN (1) TO (10) OF PART-A:

1.	Name of the Candidate	Sh./Smt./Kum. ASIT KUMAR RAY		
2.	Full postal address	AT- UPPER KAIPADA, P.O- KAIPADA P.S- BARI RAMCHANDRAPUR, DIST- TAJAPUR, ODISHA, PIN- 755010		
3.	Number and name of the constituency and State	49 - BARI ASSEMBLY CONSTITUENCY		
4.	Name of the political party which set up the candidate (otherwise write 'Independent')	HINDUSTAN NIRMAN DAL		
5.	Total number of pending criminal cases	NIL		
6.	Total number of cases in which convicted	NIL		
7.		PAN of	Year for which last income tax return filed	Total income shown
	(a) Candidate	ATAPR 7795 N	2018-19	102650/-
	(b) Spouse	NOT APPLICABLE	NOT APPLICABLE	NOT APPLICABLE
	(c) HUF	NO PAN ALLOTTED	NIL	NIL
	(d) Dependent	NOT APPLICABLE	NIL	NIL

Contd.P.14

Damod

Sarat Kd. Panigrahi
Sarat Kd. Panigrahi,
Notary Public, Jaipur

Prasid Kumar Ray

8. Details of Assets and Liabilities (including offshore assets) in rupees

Description		Self	Spouse	HUF	Dependent-I	Dependent- II	Dependent- III
A.	Moveable Assets (Total Value)	NIL	NIL	NIL	NIL	NIL	NIL
B	Immovable Asset						
	I. Purchase price of self-acquired immovable property	NIL	NIL	NIL	NIL	NIL	NIL
	II Development / construction cost of immovable property after purchase (if applicable)	NIL	NIL	NIL	NIL	NIL	NIL
	III Approximate Current Market Price -						
	(a) Self-acquired assets (Total Value)	NIL	NIL	NIL	NIL	NIL	NIL
	(b) Inherited assets (Total value)	NIL	NIL	Rs 3940000	NIL	NIL	NIL
9.	Liabilities						
	(i) Government dues (Total)	NIL	NIL	NIL	NIL	NIL	NIL
	(ii) Loans from Bank, Financial Institutions and others (Total)	NIL	NIL	NIL	NIL	NIL	NIL

Contd.P.15.

Dhand
Sarat Ru. Panigrahi,
Notary Public, Jaipur

Panigrahi



	Description	Self	Spouse	HUF	Dependent-I	Dependent- II	Dependent- III
10	Liabilities that are under dispute :						
	(i) Government dues (Total)	NIL	NIL	NIL	NIL	NIL	NIL
	(ii) Loans from Bank, Financial Institutions and others (Total)	NIL	NIL	NIL	NIL	NIL	NIL
11	Highest educational qualifications:- (Give details of highest School/University education mentioning the full form of the certificate/ diploma/ degree course, name of the School/College/ University and the year in which the course was completed.)			BACHELOR OF ARTS (ECONOMICS) HONOURS IN THE YEAR 1998 FROM DHARANIDHAR COLLEGE, KEONJHAR OF UTKAL UNIVERSITY			

VERIFICATION

I, the deponent, above named, do hereby verify and declare that the contents of this affidavit are true and correct to the best of my knowledge and belief and no part of it is false and nothing material has been concealed there from. I further declare that:-

- (a) there is no case of conviction or pending case against me other than those mentioned in items 5 and 6 Part A and B above;
- (b) I, my spouse, or my dependents do not have any asset or liability , other than those mentioned in item 7 and 8 of Part A and items 8,9 and 10 of Part B above.

Verified at Jajpur..... This the 6th Day of April 2019

Identified by me,
Jajpur,
Dt. 06.04.19
Advocate.

[Signature]

[Signature]
DEPONENT

Note:-1. Affidavit should be filed latest by 3.00 PM on the last day of filing nominations.

Note:2. Affidavit should be sworn before an Oath Commissioner or Magistrate of the First Class or before a Notary Public.

Note:3. All column should be filled up and no column to be left blank. If there is no information to furnish in respect of any item, either "Nil" or "Not applicable", as the case may be, should be mentioned.

Note:4. The Affidavit should be either typed or written legibly and neatly."

Note: 5. Each page of the Affidavit should be signed by the deponent and the Affidavit should bear on each page the stamp of the Notary or Oath Commissioner or Magistrate before whom the Affidavit is sworn.

Identified by... Sandeep K. Gopal
Advocate solemnly affirm and state before me that the contents of this affidavit are true to the best of his/her knowledge and belief

[Signature]
06-4-19
Sarat Kumar Panigrahi
Notary Public, Jajpur

[Signature]

FORM ITR-V

INDIAN INCOME TAX RETURN VERIFICATION FORM

[Where the data of the Return of Income in Form ITR-1 (SAHAJ), ITR-2, ITR-3, ITR-4(SUGAM), ITR-5, ITR-7 transmitted electronically without digital signature] .

Assessment Year

2018-19

(Please see Rule 12 of the Income-tax Rules, 1962)

PERSONAL INFORMATION AND THE DATE OF ELECTRONIC TRANSMISSION

Name ASIT KUMAR RAY		PAN ATAPR7795N	
Flat/Door/Block No UPPERKAIPADA	Name Of Premises/Building/Village		Form No. which has been electronically transmitted ITR-3
Road/Street/Post Office KAIPADA	Area/Locality Upperkai Pada		
Town/City/District JAJAPUR	State ORISSA	Pin/ZipCode 755010	Status Individual Aadhaar Number/ Enrollment ID XXXX XXXX 9848
Designation of AO (Ward / Circle) ITO, WARD JAJPUR		Original or Revised ORIGINAL	
E-filing Acknowledgement Number 443763900270319		Date(DD-MM-YY) 27-03-2019	

COMPUTATION OF INCOME AND TAX THEREON

1	Gross Total Income	1	9845
2	Deductions under Chapter-VI-A	2	345
3	Total Income	3	9500
	a Current Year loss, if any	3a	0
4	Net Tax Payable	4	0
5	Interest and Fee Payable	5	0
6	Total Tax, Interest and Fee Payable	6	0
7	Taxes Paid		
	a Advance Tax	7a	0
	b TDS	7b	0
	c TCS	7c	0
	d Self Assessment Tax	7d	0
	e Total Taxes Paid (7a+7b+7c +7d)	7e	0
8	Tax Payable (6-7e)	8	0
9	Refund (7e-6)	9	0
10	Exempt Income		
	Agriculture	102650	
	Others	0	102650

VERIFICATION

I, ASIT KUMAR RAY son/ daughter of GOKULANANDA RAY, holding Permanent Account Number ATAPR7795N solemnly declare to the best of my knowledge and belief, the information given in the return and the schedules thereto which have been transmitted electronically by me vide acknowledgement number mentioned above is correct and complete and that the amount of total income and other particulars shown therein are truly stated and are in accordance with the provisions of the Income-tax Act, 1961, in respect of income chargeable to income-tax for the previous year relevant to the assessment year 2018-19. I further declare that I am making this return in my capacity as Self and I am also competent to make this return and verify it.

Sign here

Date 27-03-2019

Place JAJPUR

If the return has been prepared by a Tax Return Preparer (TRP) give further details as below:

Identification No. of TRP	Name of TRP	Counter Signature of TRP

For Office Use Only

Receipt No

Filed from IP address 117.203.212.101

Date

Seal and signature of receiving official



ATAPR7795N034437639002703194A419DC6D0A8FFACCD71C18A91F5D7238DD113F9

Please send the duly signed Form ITR-V to "Centralized Processing Centre, Income Tax Department, Bengaluru 560500", by ORDINARY POST OR SPEED POST ONLY, within 120 days from date of transmitting the data electronically. Form ITR-V shall not be received in any other office of the Income-tax Department or in any other manner. The confirmation of receipt of this Form ITR-V at ITD-CPC will be sent to the e-mail address asitray78@gmail.com

Asit Kumar Ray

 ଭାରତୀୟ ନିର୍ବାଚନ କମିଶନ
ELECTION COMMISSION OF INDIA
IDENTITY CARD
 OR/04/028/140490



ଚୋରକର ନାମ : ଅସିତ କୁମାର ରାୟ
 Elector's Name : Asit Kumar Ray
 ପିତାଙ୍କ ନାମ : ଗୋକୁଳନନ୍ଦ ରାୟ
 Father's Name : Gokulnanda Ray
 ଲିଙ୍ଗ / Sex : ପୁରୁଷ / Male
 ଜନ୍ମ ତାରିଖ / Date of Birth : XX/XX/1982

OR/04/028/140490

ଠିକଣା :
 ଗ୍ରାମ/ଘାଟ : ଉପର କାମପାଡା
 ଗ୍ରାମ/ସହର : କାମାଟା
 ଥାନା : ବରୀ ରାମଚନ୍ଦ୍ରପୁର
 ଜିଲ୍ଲା : ରାଜସୁଥ
 Address:
 Village/Locality : Uper Kaipada
 G.P./Town : Kalamata
 P.S. : Ramachandrapur
 District : Jaipur
 Date : 15/07/2013

ବରୀ ରାମଚନ୍ଦ୍ରପୁର ନିର୍ବାଚନ ମଣ୍ଡଳୀ
 Polling Officer's Signature
 Polling Officer
 49, Bari Assembly Constituency

Do not change the name of the constituency on this card. In case of change in address, mention this card no. in the relevant form for including your name in the list at the changed address and to obtain the card with same number.

Asit Kumar Ray

आयकर विभाग
INCOME TAX DEPARTMENT

भारत सरकार
GOVT. OF INDIA

ASIT KUMAR RAY

GOKULANANDA RAY

01/07/1978
Permanent Account Number

ATAPR7795N

Asit Kumar Ray
Signature

05112008

इस कार्ड के खोने / गाने पर कृपया सूचित करें / लौटाएं:
आयकर पैन सेवा इकाई, एन एस डी एल
तीसरी मंजिल, सफ़ायर चारबर्स,
बानेर टेलिफोन एक्सचेंज के नजदीक,
बानेर, पुना - 411 045

*If this card is lost / someone's lost card is found,
please inform / return to:*
Income Tax PAN Services Unit, NSDL
3rd Floor, Sapphire Charabers,
Near Baner Telephone Exchange,
Baner, Pune - 411 045

Tel: 91-20-2721 8080, Fax: 91-20-2721 8081
e-mail: tininfo@nsdl.co.in

Asit Kumar Ray



ସୂଚନା

ଆପଣ ପରିଚୟ ପ୍ରମାଣ ଅଟେ, ନାଗରିକତାର ନୁହେଁ ।
ଆପଣଙ୍କ ପ୍ରମାଣ ଅନୁ ଭାରତ ଅପେକ୍ଷକେଶନ ଦ୍ୱାରା ପ୍ରାପ୍ତ କରନ୍ତୁ ।

INFORMATION

Aadhaar is proof of identity, not of citizenship.
Establish identity, authenticate online.

ଆପଣଙ୍କ ସାରାଦେଶରେ ବୈଧ ।

ଭବିଷ୍ୟତରେ ଏହି ଆଧାର, ସମସ୍ତ ସରକାରୀ ଓ ବେସରକାରୀ
ସେବା ପ୍ରାପ୍ତ କରିବାରେ ସାହାଯ୍ୟକରି ଦେବେ ।

Aadhaar is valid throughout the country.

Aadhaar will be helpful in availing Government
and Non-Government services in future.

Unique Identification Authority of India

Address: KAIPADA, Uperkaipada,
Kaipada, Jajapur, Odisha, 755010

9599 0040 9848

help@uidai.gov.in

www.uidai.gov.in



ଭାରତ ସରକାର
Unique Identification Authority of India
Government of India

ନମାଙ୍କନ କ୍ରମ / Enrollment No 1092/10351/58642

To,
ଅସିତ କୁମାର ରାୟ
ASIT KUMAR RAY
KAIPADA
Uperkaipada
Kaipada Jajapur
Odisha 755010

27/11/2013

Ref: 248 / 17L / 405413 / 405576 / P



SH681506309FT



ଆପଣଙ୍କ ଆଧାର ସଂଖ୍ୟା / Your Aadhaar No. :

9599 0040 9848

ଆଧାର - ସାଧାରଣ ଲୋକର ଅଧିକାର



ଭାରତ ସରକାର
Government of India



ଅସିତ କୁମାର ରାୟ
ASIT KUMAR RAY
ପିତା : ଗୋକୁଳାନନ୍ଦ ରାୟ
Father : GOKULANANDA RAY
ଜନ୍ମ ତାରିଖ / DOB : 01/07/1978
ପୁରୁଷ / Male

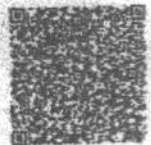

9599 0040 9848

ଆଧାର - ସାଧାରଣ ଲୋକର ଅଧିକାର

Print number 10

UTKAL UNIVERSITY

ISSUE SL. NO. 21747



PROVISIONAL CERTIFICATE

RAY ASIT KUMAR

This is to certify that

bearing Roll No. 0301K 95024 has passed the Bachelor of Arts/Science*

Commerce (Three Year Degree Course) Examination, 199 8 from

DHARANIDHAR COLLEGE, KEONJHAR

in SECOND CLASS HONOURS

His/Her Subjects were

Core-1

ENGLISH

MIL (ORIYA)

Core-2

POLITICAL SCIENCE

Core-3

ECONOMICS

(HONOURS)

Foundation Course

(1) SCIENCE IN EVERY DAY LIFE

(2) HIST OF FREEDOM MOVEMENT

Ancillary Course

RURAL INDUSTRIALISATION

Sheela

PRINCIPAL OF THE COLLEGE

Bargun

CONTROLLER OF EXAMINATIONS

Post 1992 100



भारतीय KAIPADA BANK OF INDIA
 VIA-INDUPUR, DIST: JAJPUR, ORISSA 755010
 Tel: 212604

Mr. ASIT KUMAR RAY
 KAIPADA, JAJPUR
 KAIPADA, JAJPUR
 Jajpur

12/11/2018

सावधि जमा सूचना
 (सावधि जमा स्वीत के एज में)
TERM DEPOSIT ADVICE
 (In lieu of Term Deposit Receipt)
 नामांकन / Nomination / Registered / अर्जितकृत / Not Registered
 दिनांक / Date :

प्रिय महोदय / महोदया, Dear Sir/Madam,
 हमें यह पुरष्टि करते हुए प्रसन्नता है कि आपकी निम्नलिखित राशि हमारे पास जमा है, भविष्य में, कृपया आपके पत्राचार में खाता क्रमांक का संदर्भ आशय, इस संदर्भ में सावधि जमा करने के लिए धन्यवाद। We have pleasure in confirming details of the following amount held in deposit with us. Please quote the account number in all correspondence for Banking with us.
 नाम / Name :
 सिफ संख्या / CIF No.
 पैन संख्या / PAN NO.

SINGLE

खाता संचालन की विधि: / Mode of Operation :

योजना / Scheme :
 TDR-GEN-PUB IND-7D-45D-INR

खाता क्रमांक / A/c No. 38065345767	सावधि / Term 14 D	ब्याज दर Interest @ 5.75 %	मूल राशि Principal Amt. 1,00,000.00	जारी करने की तारीख Value Date 12.11.2018	परिपक्वता की तारीख Maturity Date 26.11.2018
---------------------------------------	----------------------	-------------------------------	--	---	--

आवधिक मूल्य / Annualised Value : INR-1,00,221.00
 परिपक्वता की तारीख / Maturity Value : INR 5.76

Printed 1 Times

भवदीय / Yours faithfully,



Authorised Signatory
 कृपया पृष्ठ फलटें / P.T.O.

यह प्रकाम्य लिखत नहीं है This is not a Negotiable Document

Asit Kumar Ray



KAPADA ATOK KAPADA Bank of India
VIA-INDUPUR, DIST. JAJPUR, ORISSA 755010
Tel: 212604

Mr. ASIT KUMAR RAY
KAIPADA, KAIPADA, JAJPUR
JAJPUR
Jajapur

27/11/2018

नामांकन / Nominal / Registered / अप्रजिंकृत / Not Registered
दिनांक / Date :

सावधि जमा सूचना
(सावधि जमा खाते के पत्र में)
TERM DEPOSIT ADVICE
(In lieu of Term Deposit Receipt)

प्रिय महोदय / महोदया, Dear Sir/Madam,
हमें यह सुनिश्चित करने का प्रयत्न है कि आपकी निम्नलिखित शर्तों के अनुसार जमा है, भविष्य में, कृपया आपके पत्राचार में खाता क्रमांक का संदर्भ **ASIT KUMAR RAY** के बिना करने के लिए धन्यवाद। We have pleasure in confirming details of the following amount held in deposit with us. Please quote the account number in all correspondence for Banking with **WAPR7795N**
नाम / Name: सिर्फ संख्या / CIF No. पैन संख्या / PAN NO.

SINGLE
खाता संभालन की विधि: / Mode of Operation :
TDR-GEN-PUB IND-7D-45D-1NR
योजना / Scheme :

खाता क्रमांक / A/c No. 38090594483	सावधि / Term 14 D	व्याज दर Interest @ 5.75 %	मूल राशि Principal Amt. 1,00,000.00	जारी करने की तारीख Value Date 27/11/2018	परिपक्वता की तारीख Maturity Date 11.12.2018
---------------------------------------	----------------------	-------------------------------	---	--	---

आवधिकृत / Authorised Signatory
Maturity Value : INR 1,00,221.00

Printed 1 Times

सावधिकृत / Authorised Signatory
कृपया पत्र पते / P.T.O.



Asit Kumar Ray

ଭାରତ ନିର୍ବାଚନ ଆୟୋଗ
ELECTION COMMISSION OF INDIA
ଭାରତ ଚିତ୍ରାଣୁ ପତ୍ର - ELECTOR PHOTO IDENTITY CARD

SXX0987370



ନାମ : ଶୈଳୟା କୁମାର ରାୟ
ପିତାଙ୍କ ନାମ : ଗିରିଶ କୁମାର ରାୟ
Father's Name : Girish Kumar Ray

ଲିଙ୍ଗ/Sex : ପୁରୁଷ / Male
ଜନ୍ମ ତାରିଖ/ବୟସ (Date of Birth/Age) : 24/05/1996
ଠିକଣା :
ଗ୍ରାମ/ସ୍ଥାନ : ଉପର କାଲପାଡ଼ା ଗ୍ରାମପଞ୍ଚାୟତ
କଳାମାଟିଆ ଥାନା - ବରୀ କାମଚନ୍ଦ୍ରପୁର ଜିଲ୍ଲା
Address :
Village/Locality - Upar Kaipada G.P/Town
- Kalamatia P.S. - Ramachandrapur
District - Jajpur

Date : 5/9/2016

ନିର୍ବାଚନ ରେକର୍ଡିଂ ଅଫିସର
Electoral Registration Officer

49-ବରୀ ବିଧାନସଭା ନିର୍ବାଚନ ମଣ୍ଡଳୀ
49-Bari Assembly Constituency
ଭାଗ ନଂ-୩୩-୧୦୮ ନାମ : 235-ଉପର କାଲପାଡ଼ା
Part No and Name: 235-Upar Kaipada
ଟିପ୍ପଣୀ/ Note:
ଏ କାର୍ଡ ଧରିବା ଉପରେ କେବଳ ଏକଥା ଗ୍ୟାଣ୍ଟି କରାଯାଏ ଯେ ଉପରୋକ୍ତ ତଥ୍ୟ ସତ୍ୟ ଅଟେ । ଏହା କେବଳ ଏକ ପ୍ରମାଣ ପତ୍ର ନୁହେଁ ।
Mere possession of this card is no guarantee that you are elector in the current electoral roll. Please check your name in the current electoral roll before every election.
ଏ କାର୍ଡ ଧରିବା ଉପରେ କେବଳ ଏକଥା ଗ୍ୟାଣ୍ଟି କରାଯାଏ ଯେ ଉପରୋକ୍ତ ତଥ୍ୟ ସତ୍ୟ ଅଟେ । ଏହା କେବଳ ଏକ ପ୍ରମାଣ ପତ୍ର ନୁହେଁ ।
Date of birth mentioned in this card shall not be treated as a proof of age/D.O.B. for any purpose other than registration in electoral roll.

PART NO - 223
S. No. In THE PART - 636

Signature → Soundarya Kumar Ray

ଭାରତ ନିର୍ବାଚନ ଆୟତନ
 ELECTION COMMISSION OF INDIA
 ଭାରତ ବିଦ୍ୟୁତ୍ ଚିତ୍ର ପଞ୍ଜୀକରଣ କାର୍ଡ - ELECTOR PHOTO IDENTITY CARD

SXX1016377



ନାମ : ଡେବାଶିସ୍ ପରିଡ଼ା
 ପିତାଙ୍କ ନାମ : ନିଳମଣି ପରିଡ଼ା
 ଫାଦର's Name : Nilamani Parida

LXX1016377

ଲିଙ୍ଗ/ସେକ୍ସ : ପୁରୁଷ / Male
 ଜନ୍ମ ତାରିଖ/ବୟସ (Date of Birth/Age) : 05/04/1000
 ଠିକଣା :
 ଗ୍ରାମ/ସ୍ଥାନ : ଉପର କାଲପାଡ଼ା ଗ୍ରାମପଞ୍ଚାୟତ
 ବିଧାନସଭା ଅଞ୍ଚଳ : ବରାକାମଚନ୍ଦ୍ରପୁର ବିଧାନ
 ଠିକଣା :
 Village/Locality - Upar Kalpada G.P/Town
 - Kalamatia P.S. - Ramachandrapur
 District - Jajpur
 Date : 17/1/2017

ଭାରତ ନିର୍ବାଚନ ଆୟତନ
 ELECTION COMMISSION OF INDIA
 ଭାରତ ବିଦ୍ୟୁତ୍ ଚିତ୍ର ପଞ୍ଜୀକରଣ କାର୍ଡ - ELECTOR PHOTO IDENTITY CARD

ଭାରତ ନିର୍ବାଚନ ଅଧିକାରୀ
 Electoral Registration Officer
 49-Bari Assembly Constituency
 ଭାରତ ବିଧାନ ସଭା ନାମ : 235-ଉପର କାଲପାଡ଼ା
 Part No and Name: 235-Upar Kalpada
 ଟିପ୍ପଣୀ/ Note:
 ଏହି କାର୍ଡ ଉପରେ କୌଣସି ନିର୍ବାଚନ ପ୍ରକ୍ରିୟାରେ ଏହାକୁ ପ୍ରମାଣିତ ଭାବରେ ବ୍ୟବହାର କରିବାକୁ କୌଣସି ନିର୍ଦ୍ଦେଶ ନାହିଁ।
 Mere possession of this card is no guarantee that you are elector in the current electoral roll. Please check your name in the current electoral roll before every election.
 ଏହି କାର୍ଡ ଉପରେ କୌଣସି ନିର୍ବାଚନ ପ୍ରକ୍ରିୟାରେ ଏହାକୁ ପ୍ରମାଣିତ ଭାବରେ ବ୍ୟବହାର କରିବାକୁ କୌଣସି ନିର୍ଦ୍ଦେଶ ନାହିଁ।
 Date of Birth mentioned in this card shall not be treated as a proof of age/D.O.B. for any purpose other than registration in electoral roll.

part no - 223
 S. No - In the part - 907

Signature - *α* Debashis Parida

 ଭାରତୀୟ ନିର୍ବାଚନ କମିଶନ
ELECTION COMMISSION OF INDIA
IDENTITY CARD
 SXX0407908



ଭୋଟରଙ୍କ ନାମ : ସ୍ଵର୍ଣ୍ଣଦୀପ ରାୟ
 Elector's Name : Swarnadeep Ray
 ପିତାଙ୍କ ନାମ : ବାବୁରାମ ରାୟ
 Father's Name : Baburam Ray
 ଲିଙ୍ଗ / Sex : ପୁରୁଷ / Male
 ଜନ୍ମ ତାରିଖ / Date of Birth : 09/05/1982

ଠିକଣା : SXX0407908

ଗ୍ରାମ/ଘାଟ : ଉପର କାଇପଡା
 ଗ୍ରାମ/ସହର : କଳାମାଟିଆ
 ଥାନା : ବରୀ ରାମଚନ୍ଦ୍ରପୁର
 ଜିଲ୍ଲା : ସାକସୁର
 Address:
 Village/Locality : Upar Kaipada
 G.P/Town : Kalamatia
 P.S. : Ramachandrapur
 District : Jaipur

Date : 05/01/2012
 ଦ୍ଵାରା ସ୍ଵାକ୍ଷରଣ କରାଯାଇଛି
 ନିର୍ବାଚନ ରେଜିଷ୍ଟ୍ରାର ଅଧିକାରୀଙ୍କ ଦ୍ଵାରା
 Facsimile Signature of
 Electoral Registration Officer
 49, Bari Assembly Constituency

ଠିକଣା ପରିବର୍ତ୍ତନ ହେଲେ ଏହି କାର୍ଡ ନମ୍ବର ସହିତ ନିଜର ପୁରୁଣା ଠିକଣା ଉପରେ ଏହି କାର୍ଡ ପୁନଃ ଉପଲବ୍ଧ କରିବା ପାଇଁ ଏକ ସ୍ଵତନ୍ତ୍ର ଫର୍ମ ପୂରଣ କରିବାକୁ ପଡ଼ିବ।
 In case of change in address, mention this card no. in the relevant form for including your name in the roll at the changed address and to obtain the card with same number.

Part no - 223
 S.N. no - 569

Signature - Swarna deep Ray

ଭାରତୀୟ ନିର୍ବାଚନ କମିଶନ
ELECTION COMMISSION OF INDIA
 CTY1180819

ପରିଚୟ ପତ୍ର
IDENTITY CARD



ଛୋଟରଙ୍ଗ ନାମ : ସୁନାକର ପରିଡ଼ା
 Elector's Name : Sunakar Parida
 ପିତାଙ୍କ ନାମ : ଲମ୍ବୋଦର ପରିଡ଼ା
 Father's Name : Lambodar Parida
 ଲିଙ୍ଗ / Sex : ପୁରୁଷ / Male
 ୦୧/୦୧/୨୦୦୮ ରେ ବୟସ : ୨୧
 Age as on 01/01/2008 : 21

CTY1180819

ଠିକଣା :

ଗ୍ରାମ/ଘାଟ : ଉପର କାଲପା
 ଗ୍ରାମ/ସହର : କାଲମାଟିଆ
 ଥାନା : ବରୀ-ରାମଚନ୍ଦ୍ରପୁର
 ଜିଲ୍ଲା : ସାବରମତୀ
 Address :
 Village/Ward : Upar Kaipada
 G.P/Town : Kalamatia
 P.S. : Bari-Ramachandrapur
 District : Jajpur

ଏହି ପରିଚୟ ପତ୍ର ବିଭିନ୍ନ ସରକାରୀ ଯୋଜନାରେ
 ପରିଚୟ ପତ୍ର ରୂପେ ବ୍ୟବହାର କରାଯାଇପାରିବ ।
 This card can be used as an Identity card
 Under different Government Programmes.

ସାବରମତୀ : ବରି ଚୋରାବିଶି
 Jajpur : ବିଧାନସଭା ନିର୍ବାଚନ ମଣ୍ଡଳୀର
 ନିର୍ବାଚନ ଅଧିକାରୀଙ୍କ ଅଧିକାରୀଙ୍କ ଦସ୍ତଖତ
 ୧୦/୦୧/୨୦୦୮ : Facsimile Signature of
 10/01/2008 : Electoral Registration Officer
 For Bari-Derabisi AC

part no - 223

S. No In the part - 411

Signature
 ↓
 Sunakar Parida

 ଭାରତୀୟ ନିର୍ବାଚନ କମିଶନ
ELECTION COMMISSION OF INDIA
IDENTITY CARD
 SXX0407700



ଚୋଷରଙ୍କ ନାମ : ସମିରକାନ୍ତ ରାୟ
 Elector's Name : Samirakanta Ray
 ପିତାଙ୍କ ନାମ : ଚନ୍ଦ୍ରମଣି ରାୟ
 Father's Name : Chandramani Ray
 ଲିଙ୍ଗ / Sex : ପୁରୁଷ / Male
 ଜନ୍ମ ତାରିଖ / Date of Birth : XX/XX/1989

SXX0407700

ଠିକଣା :
 ଗ୍ରାମ/ସ୍ଥାନ : ଉପର କାଲପଡା
 ଗ୍ରାମ/ସହର : କଳାମାଟିଆ
 ଥାନା : ବରୀ ରାମଚନ୍ଦ୍ରପୁର
 ଜିଲ୍ଲା : ଯାଜପୁର
 Address :
 Village/Locality : Upar Kaipada
 G.P/Town : Kalamatia
 P.S. : Ramachandrapur
 District : Jajpur
 Date : 05/01/2012

ବରୀ ବିଧାନସଭା ନିର୍ବାଚନ ମଣ୍ଡଳୀର
 ନିର୍ବାଚନ ରେଜିଷ୍ଟ୍ରାର୍‌ଙ୍କ ଦ୍ଵାରା ପ୍ରଦତ୍ତ ଦସ୍ତଖତ
 Facsimile Signature of
 Electoral Registration Officer
 49, Bari Assembly Constituency

ଠିକଣା ପରିବର୍ତ୍ତନ ହେତୁ ନିଜର ନିଜସ୍ଵ ଠିକଣା ଉପରେ ଉପରୋକ୍ତ
 କାର୍ଡ ଠିକ୍ କରାଯାଇ ଏହାକୁ ନିଜର ନିଜସ୍ଵ ଠିକଣା ଠିକ୍
 କରିବା ପାଇଁ ଏହି କାର୍ଡ ସହିତ ସମ୍ପର୍କ କରନ୍ତୁ ।
 In case of change in address, mention this card no. in the
 relevant form for including your name in the roll at the
 changed address and to obtain the card with same number.

Signature - SAMIRA KANTA RAY

part no - 223
 S. no for the part - 682

ELECTION COMMISSION OF INDIA
 ଭାରତୀୟ ନିର୍ବାଚନ କମିଶନ
 OR/04/028/142166

IDENTITY CARD
ପରିଚୟ ପତ୍ର



Elector's Name : Managobind Parida
 ଭୋଟରଙ୍କ ନାମ : ମାନଗୋବିନ୍ଦ ପରିଡ଼ା
 Father's Name : Balaram Parida
 ପିତାଙ୍କ ନାମ : ବଳରାମ ପରିଡ଼ା
 Sex / ଲିଙ୍ଗ : Male / ପୁରୁଷ
 Age as on 01/01/2004 : 37
 ୦୧.୦୧.୨୦୦୪ ରେ ବୟସ : ୩୭

OR/04/028/142166

Address :

Village/Ward : Upara kaipada
 G.P./Town : Kalamatia
 P.S. : Bari-Ramachandrapur
 District : Jajpur
 ଠିକଣା :
 ଗ୍ରାମ/ଓର୍ଡ : ଉପରା କାୟପାଡ଼ା
 ଗ୍ରାମ/ପଞ୍ଚାୟତ : କାଲାମାଟିଆ
 ଥାନା : ବରୀ-ରାମଚନ୍ଦ୍ରପୁର
 ଜିଲ୍ଲା : ଯାଜପୁର

This card can be used as an Identity card
 Under different Government Programmes.
 ଏହି ପରିଚୟ ପତ୍ର ବିଭିନ୍ନ ସରକାରୀ ଯୋଜନାରେ
 ପରିଚୟ ପତ୍ର ରୂପେ ବ୍ୟବହାର କରାଯାଇପାରିବ ।

Jajpur : ଯାଜପୁର
 10/03/2004
 ୧୦/୦୩/୨୦୦୪

Facsimile Signature of
 Electoral Registration Officer
 For Bari-Derabis AC
 ବରୀ-ଡେରାବିଶି
 ବିଧାନସଭା ନିର୍ବାଚନ ମଣ୍ଡଳୀର
 ନିର୍ବାଚନ ରେଜିଷ୍ଟ୍ରାରର ଅଧିକାରୀଙ୍କ ପକ୍ଷରୁ

part no - 223
S. No - 893

Signature -

Managobind Parida



ELECTION COMMISSION OF INDIA

ଭାରତୀୟ ନିର୍ବାଚନ କମିଶନ

IDENTITY CARD OR/04/028/140155
ପରିଚୟ ପତ୍ର



Elector's Name : Mayadhar Sahu
 ଭୋଟରଙ୍କ ନାମ : ମାୟାଧର ସାହୁ
 Father's/Mother's/Husband's Name : F - Hadibandhu Sahu
 ପିତା/ମାତା/ସ୍ୱାମୀଙ୍କ ନାମ : ଫି - ହାଡିବନ୍ଧୁ ସାହୁ
 Sex / ଲିଙ୍ଗ : Male ପୁରୁଷ
 Age as on 1.1.1995: 24
 e.e.୧୯୯୫ରେ ବୟସ : ୨୪

Address :
 Vill./Ward : Uperkaipada Bidrupa
 G.P./Town : Angeisapur
 P.S. : Binjharpur
 Dist. : Jajpur

ଠିକଣା :
 ଗ୍ରାମ/ଘାଟ : ଉପରକାଉପଡା ବିଦ୍ରୁପା
 ଗ୍ରାମ/ସହର : ଅଙ୍ଗୈସାପୁର
 ଥାନା : ବିଞ୍ଜାହପୁର
 ଜିଲ୍ଲା : ଯାଜପୁର

This card can be used as an Identity Card under different Government Programmes.

ଏହି ପରିଚୟ ପତ୍ର ବିଭିନ୍ନ ସରକାରୀ ଯୋଜନାରେ ପରିଚୟ ପତ୍ର ରୂପେ ବ୍ୟବହାର କରାଯାଇପାରିବ ।

Kendrapara
 କେନ୍ଦ୍ରାପଡା
 15/01/95
 ୧୫/୦୧/୯୫

Facsimile Signature of
 Electoral Registration Officer
 for Bari-Derabisi A.C.
 ବରି-ଡେରାବିସି
 ବିଧାନସଭା ନିର୍ବାଚନ ମଣ୍ଡଳୀର ନିର୍ବାଚନ
 ରେଜିଷ୍ଟ୍ରାରଙ୍କ ଅଫିସରଙ୍କ ଦସ୍ତଖତ

part no - 223
 S.L no - 251

Signature - Mayadhar Sahu

 ଭାରତୀୟ ନିର୍ବାଚନ କମିଶନ
 ELECTION COMMISSION OF INDIA
 CTY19444562

ପରିଚୟ ପତ୍ର
 IDENTITY CARD



ଭୋଟରଙ୍କ ନାମ : ରାଜେନ୍ଦ୍ର ସାହୁ
 Elector's Name : Rajendra Sahu
 ପିତାଙ୍କ ନାମ : ନିରାଜନ ସାହୁ
 Father's Name : Nirajanna Sahu
 ଲିଙ୍ଗ / Sex : ପୁରୁଷ / Male
 02/02/2007 ରେ ବୟସ : ୧୯
 Age as on 02/02/2007 : 19

CTY19444562

ଗ୍ରାମ/ଓଡ଼ : ଉପର କାଲପଡ଼ା
 ଗ୍ରାମ/ସହର : କାଲମାଟିଆ
 ଥାନା : ବରୀ-ରାମଚନ୍ଦ୍ରପୁର
 ଜିଲ୍ଲା : ସାଗରପୁର
 Address :
 Village/Ward : Upar Kalpada
 G.P/Town : Kalamatia
 P.S. : Bari-Ramachandrapur
 District : Jajpur

ଏହି ପରିଚୟ ପତ୍ର ବିଭିନ୍ନ ସରକାରୀ ଯୋଜନାରେ
 ପରିଚୟ ପତ୍ର ରୂପେ ବ୍ୟବହାର କରାଯାଇପାରିବ ।
 This card can be used as an Identity card
 Under different Government Programmes.

ସାଗରପୁର : ବରି ଦେବାବିଶ
 Jajpur : ବିଧାନସଭା ନିର୍ବାଚନ ମଣ୍ଡଳୀର
 ନିର୍ବାଚନ ରେଜିଷ୍ଟ୍ରାର ଅଧ୍ୟକ୍ଷଙ୍କ ଦସ୍ତଖତ
 02/02/2007 : Facsimile Signature of
 08/02/2007 : Electoral Registration Officer
 For Bari-Derabisi AC

part No - 223



S.L - No - 331

Signature -

Rajendra Sahu

ELECTION COMMISSION OF INDIA
 ଭାରତୀୟ ନିର୍ବାଚନ କମିଶନ
IDENTITY CARD
 ପରିଚୟ ପତ୍ର

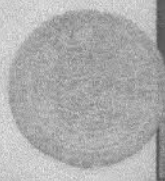
CTY1451137

Elector's Name	: Prakash Chandra Ray
ଭୋଟରଙ୍କ ନାମ	: ପ୍ରକାଶ ଚନ୍ଦ୍ର ରାୟ
Father's Name	: Sachchidananda Ray
ପିତାଙ୍କ ନାମ	: ସଚ୍ଚିଦାନନ୍ଦ ରାୟ
Sex / ଲିଙ୍ଗ	: Male / ପୁରୁଷ
Age as on 01/01/2002	: 18
୦୧.୦୧.୨୦୦୨ରେ ବୟସ	: ୧୮

CTY1451137

Address :

Village/Ward	: Upara kaipada
G.P/Town	: Anyaspur
P.S.	: Binjharpur
District	: Jajpur

ଠିକଣା :

ଗ୍ରାମ/ଭାର୍ଡ	: ଉପର କାଇପଡା
ଗ୍ରାମ/ସହର	: ଅନ୍ୟାସପୁର
ଥାନା	: ବିଞ୍ଜାରପୁର
ଜିଲ୍ଲା	: ଜାଜପୁର

This card can be used as an Identity card
 Under different government Programmes.
 ଏହି ପରିଚୟ ପତ୍ର ବିଭିନ୍ନ ସରକାରୀ ଯୋଜନାରେ
 ପରିଚୟ ପତ୍ର ରୂପେ ବ୍ୟବହାର କରାଯାଇପାରିବ ।

Jajpur	Facsimile Signature of
ଜାଜପୁର	Electoral Registration Officer
25/03/2002	For Bari-Debarish
୨୫/୦୩/୨୦୦୨	ବରି-ଡେରାବିଶ
	ବିଧାନସଭା ନିର୍ବାଚନ ମନ୍ତ୍ରଣାଳୟ
	ନିର୍ବାଚନ ରେଜିଷ୍ଟ୍ରାର୍‌ସ ଅଫିସରଙ୍କ ଦଫ୍ତର

Post no - 223

S.L.No - 670

Signature -

Prakash Chandra Ray

ଭାରତ ବିଚାରଣ ଆୟତନ
 ELECTION COMMISSION OF INDIA
 ଭାରତ ପଞ୍ଜୀକରଣ ପତ୍ର - ELECTORAL ROLL IDENTITY CARD
 SXX0533281

 ନାମ : ପ୍ରସନ୍ତ କୁମାର ପରିଡ଼ା
 Name : Prasanta Kumar Parida
 ପିତାଙ୍କ ନାମ : ପ୍ରେମାନନ୍ଦ ପରିଡ଼ା
 Father's Name : Premananda Parida

ଲିଙ୍ଗ/Sex : ପୁରୁଷ / Male
 ଜନ୍ମ ତାରିଖ/ବୟସ (Date of Birth/Age) : 19/06/1991
 ଠିକଣା :
 ଗ୍ରାମ/ସ୍ଥାନ - ଉପର କାମପଡ଼ା ଗ୍ରାମପଞ୍ଚାୟତ
 କଳାମତିଆ ଥାନା - ବରପାଳାମନ୍ଦ୍ରପୁର ଜିଲ୍ଲା
 ଠିକଣା :
 Village/Locality - Upar Kaipada G.P/Town
 - Kalamatia P.S. - Ramachandrapur
 District - Jajpur
 Date : 17/1/2017
 ନିର୍ବାଚନ ରେଜିଷ୍ଟ୍ରାର ଅଧିକାରୀ
 Electoral Registration Officer
 49-ବରପାଳାମନ୍ଦ୍ରପୁର ନିର୍ବାଚନ ମଣ୍ଡଳୀ
 49-Bari Assembly Constituency
 ନାମ ସଂଖ୍ୟା ଏବଂ ନାମ : 235-ଉପର କାମପଡ଼ା
 Part No and Name: 235-Upar Kaipada
 ଟିପ୍ପଣୀ/ Note:
 ଏ ଆକାରରେ ଏହି ପତ୍ରର କୌଣସି ପ୍ରକାରରେ ବିଶ୍ୱାସ କରିବା କିମ୍ବା ଏହାକୁ କୌଣସି ପ୍ରକାରରେ ପ୍ରମାଣିତ କରିବା ନିମନ୍ତେ କୌଣସି ଗ୍ୟାରେଣ୍ଟି ନାହିଁ ।
 Mere possession of this card is no guarantee that you are elector in the current electoral roll. Please check your name in the current electoral roll before every election.
 ଏହି ପତ୍ରର କୌଣସି ପ୍ରକାରରେ ଏହାକୁ କୌଣସି ପ୍ରକାରରେ ପ୍ରମାଣିତ କରିବା ନିମନ୍ତେ କୌଣସି ଗ୍ୟାରେଣ୍ଟି ନାହିଁ ।
 Date of Birth mentioned in this card shall not be treated as a proof of age/D.O.B. for any purpose other than registration in electoral roll.

Part no - 223
 S.L. No - 577

Signature → Prasanta Parida

Checklist of documents in connection with filing of nomination

Name of constituency 49 - Bari
 Name of the candidate Amit Kumar Ray
 Date and time of filing nomination paper 08.04.2019 at 11:11 AM
 Sl. No. of nomination paper 13/LA/2019/RO-49-Bari, A.C

Sl. No.	Documents	Whether filed (Write Yes/No) [if there is any defect/shortcoming in the documents, the same should be specified]
1	Affidavit in Form 26— (a) Whether all columns are filled up (b) If not, which are blank column(s) (Please specify): (c) Whether the affidavit is sworn before an Oath Commissioner or Magistrate of First Class or before a Notary Public.	Yes All columns are filled up. Yes, Notary - Public
2	Certified extract of electoral roll (when candidate is an elector of a different constituency).	No
3	Form A and B (applicable in the case of candidates set up by political parties).	Yes
4	Copy of caste certificates (if the candidate claims to belong to SC/ST).	No
5	Security deposit (whether made)	Yes
6	Oath and affirmations (whether taken)	Yes

The following documents which have not been filed should be filed as indicated below :

(a) NIL should be filed latest by NIL

(b) Above-mentioned columns in the Affidavit in Form 26 have been left blank. You must submit a revised Affidavit with columns duly filled up before the commencement of scrutiny of nominations, failing which the nomination paper will be liable to be rejected.

(c) NIL should be filed latest by NIL

Received

Amit Kumar Ray

(Signature of candidate)

Date & Time :

Place :

N. B.

- The affidavit in Form 26 and Forms A & B have to be filed latest by 3-00 P.M. on the last date of filing nominations.
- If columns have been left blank in the affidavit in Form 26, this should be specified against item 1, and candidate should be asked to submit an affidavit complete in all respect, latest by the time fixed for commencement of scrutiny of nominations. Failure to submit revised affidavit complete in all respects, even after reminder by RO will be a ground for rejection of the nomination paper.
- Oath has to be taken after filing nomination paper and before the date fixed for scrutiny
- Certified extract of electoral roll can be filed up to the time of scrutiny

Amit Kumar Ray
 Returning Officer.
 (Signature of RO/ARO)
 49-Bari,

Assembly Constituency

NOTICE

Please take notice that the allotment of Election Symbols to the contesting candidate from 49-Bari Assembly constituency in simultaneous General Election-2019 shall be taken up at 3 PM on 12th of April 2019 at the Office Chamber of RO. & Addl.Sub-Collector, Jajpur. Room No.2 Collectorate, Jajpur

You are therefore informed to remain present by person/through your Election agent at the above mentioned place, date, and time.

Returning Officer,
RO, 49-Bari AC-cum-Addl.
Sub-Collector, Jajpur
49-Bari
Assembly Constituency

Post kumr 19

ACKNOWLEDGEMENT FORM

To

The Returning Officer,
49-Bari Assembly Constituency

Sir,

I acknowledge receipt of your letter No.....16.....dated..08.04.2019 along with its enclosures containing , among other documents, a Register bearing serial No.....35 Page: 132 for maintaining of my accounts of election expenses.

2. I have noted the requirements of law for maintenance of account of election expenses and lodging of true copy of that account with the District Election Officer/Returning Officer.

Yours faithfully

Prithvi Kumar Singh

(Signature of the Candidate with date)